



PDS23 Solar Pump Controller User Manual

Preface

Thank you for using PDS23 series products. This manual provides you with relevant operation instructions and detailed description of parameters. Please read this manual carefully before installation, running, maintenance or inspection.

Please make sure the wiring and the pump's rotation direction is correct before use.

Content

Preface	- 1 -
Notes for Safe Operation	- 4 -
Chapter 1 How It Works	- 6 -
1.1 Features.....	- 8 -
Chapter 2 General Information	- 10 -
2.1 Inspection.....	- 10 -
2.2 Descriptions and Features.....	- 10 -
2.3 Protection Features.....	- 11 -
2.4 PDS23 Solar Pump Controller Model Description.....	- 12 -
2.5 Outline & Installation Dimensions.....	- 17 -
Chapter 3 Mechanical and Electrical Installation	- 20 -
3.1 Mechanical Installation.....	- 20 -
3.2 Electrical Installation.....	- 21 -
Chapter 4 Start-up and Operation	- 27 -
4.1 Keypad Description.....	- 27 -
4.2 Keypad Operation Process.....	- 28 -
4.3 Trial operation.....	- 29 -
4.4 Running status panel display parameters.....	- 30 -
4.5 User Definable Parameters.....	- 31 -
Chapter 5 Diagnostics and Troubleshooting	- 36 -
5.1 Fault Codes.....	- 36 -

5.2 Common Faults and Remedies.....	- 40 -
Chapter 6 Regular maintenance.....	- 42 -
6.1 Controller and Pump.....	- 42 -
6.2 Solar panels.....	- 42 -
6.3 Cable.....	- 42 -
Chapter 7 Backup AC power.....	- 43 -

Notes for Safe Operation

■ Before Installation



WARNING

Do not install or operate the controller that is damaged or has missing parts. Otherwise, it may result in equipment damage or harm life.

■ Installation



CAUTION

- ◎ Hold the bottom of the controller when installing or moving the controller, can not just hold the shell to prevent the injured or broken controller.
- ◎ Install the controller on nonflammable material like metal. Otherwise it may cause a fire.
- ◎ When the controller is mounted in a protective cabinet, the cabinet need to set vents to ensure ambient temperature is below 40°C, otherwise it may be damaged because of high temperature.
- ◎ When install the controller, you should avoid direct sunlight, can be installed under the PV array.



WARNING

- ◎ Ensure only qualified personnel to operate. Otherwise it can cause an electrical shock or damage of the controller.
- ◎ Make sure the controller is isolated from power supply by the circuit breaker. Otherwise it may cause a fire.
- ◎ Make sure that the ground terminal  is grounded correctly.
- ◎ Do not touch the power input terminals of the controller and the pump's terminals . Otherwise it may cause an electrical shock.

■ Operation



- ◎ Do not open or remove the front cover when operation. Otherwise it may cause an electrical shock.
- ◎ Before testing the pump must be installed; can not make the pump dry-run for a long time. In order to test the pump, the maximum dry-run time is not more than 15s
- ◎ If the pump turning is reversed, it can change any two lines of the pump's three power lines.
- ◎ When the water pump is due to the light shadow, it will restart the operation after 120s.
- ◎ If a water level probe is installed in the well, when the water level is below the level of water shortage, the water pump will stop. If there is no water level probe, it will need to be short. If a water level probe is not used, the controller terminal must be short.

■ Maintenance and check



- ◎ Only qualified or authorized professional personnel can maintain, replace and inspect the controller. Otherwise it may cause damage and injury.
- ◎ Wait at least 10 minutes after the power failure, or make sure that is no residual voltage before carry out maintenance and inspection, otherwise it may cause damage.

■ Others



- ◎ If failing to follow these instructions, resulting in damage to the machine, can not enjoy the warranty service.

Chapter 1 How It Works

The PDS23 solar pumping system serves to provide water in remote applications where electrical grid power is either unreliable or unavailable. The controller can convert DC from the PV array to AC, and drive kinds of pumps. In sunny days, the PDS23 solar pumping system can continuously pump water. The system without batteries and other energy storage devices, it is recommended to take water pumped to a reservoir for later use and water sources are those natural or special such as river, lake, well or waterway, etc. A float switch can be installed in the water tower to control the pump operation. And install a low-level probe in well to detect the well water so that when the water shortage pump is stopped. Figure 1 shows a typical diagram of a PDS23 solar pumping system. The major parts and components in the system are listed after the diagram.

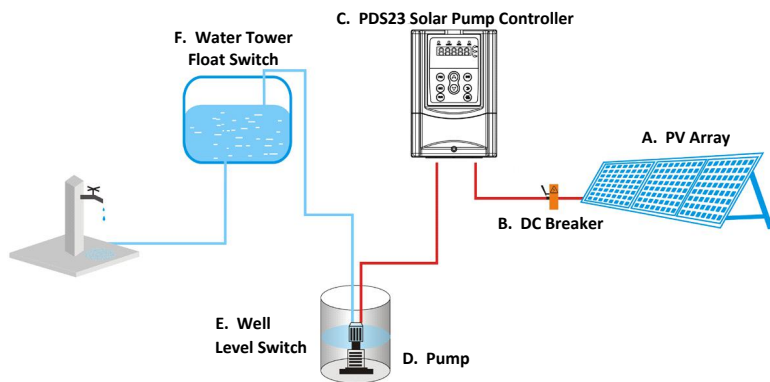

Figure 1 PDS23 solar pumping system

The PDS23 solar pumping system is designed which consists of:

- A. Solar Array
- B. DC Breaker or Disconnect Switch

C. PDS23 series Solar Pump Controller

D. Pump and Motor

E. Water Source Level Switches (optional)

F. Tank Level Switches (optional)

The PDS23 solar pump controller runs at variable speed while match the changing power provided by the solar array. Variable speed operation means there is no in-rush or surge of energy during the pump/motor start-up, helping to eliminate wear on the motor and pumping system.

Pump Check Valve Requirements

Notice: In order to ensure maximum system reliability and water delivery, check valves must be installed in the drop pipe. The first check valve must be installed at the pump and additional check valves should be installed every 30m (100 ft) of vertical pipe after the pump.

1.1 Features

System Diagnostics

The PDS23 solar pump controller continuously monitors system performance and detects a variety of abnormal conditions. In many cases, the controller will compensate as needed to maintain continuous system operation; however, if there is high risk of equipment damage, the controller will protect the system and display the fault condition. If possible, the controller will try to restart itself when the fault condition subsides. See Diagnostics and Troubleshooting section for a list of Fault Codes and corrective actions.

Motor Soft-Start

Normally, when there is a demand for water and power is available, the PDS23 solar pump controller will be operating. Whenever the PDS23 solar pump controller detects a need for water, the controller always “ramps up” the motor speed while gradually increasing motor voltage, resulting in a cooler motor and lower start-up current compared to conventional water systems. Due to the controller’s soft-start feature this will not harm the motor.

Over Temperature Foldback

The PDS23 solar pump controller is designed for full power operation from a solar array in ambient temperatures up to 45 °C. In excess of 45 °C temperature conditions , the controller will reduce output power in an attempt to avoid shutdown. Full pump output is restored when the controller temperature cools to a safe level.

Level Control Switch

The PDS23 solar pump controller can access two water level switch detects remotely control the pump automatically. Level switch for PDS23 solar pump controller is optional, not mandatory.

Switching to Backup AC Power

The PDS23 solar pump controller's input power terminal may be switched manually to a backup AC power source.

Note: Depending on the model number, PDS23 solar pump controllers support power input either 220VAC single phase, or 380VAC three phase, Please contact controller manufacturer or authorized agencies for details.

When the system is running on back-up AC power, please check for sufficient DC primary source power every 30 minutes. If the primary DC power is available, shut down the controller, switch back to primary power and attempt to run on DC power supply.

NOTICE : A DC circuit switch and a generator power switch must be installed, and these two switches must be mechanically interlocked each other to prevent switching on together resulting the solar PV and the generator being connected to the solar PDS23 solar pump controller simultaneously! Please check if the design is in accordance with all applicable national and local electrical codes.

Chapter 2 General Information

The PDS23 solar pump controller is a variable speed motor drive designed to run any IEC three-phase asynchronous motor. The PDS23 solar pumping system provides water to remote locations by converting high voltage, direct current from a solar array into alternating current to run a standard three-phase asynchronous motor. When solar power is not available, the controller can be switched manually to an alternate single-phase or three-phase AC input such as a generator or inverter from battery, if available. The controller provides fault detection, motor soft start, and speed control. The PDS23 solar pump controller is designed to provide these features with the plug and play ease of installation.

The PDS23 solar pump controller is designed with the high standard of reliability expected of products. The controller attempts to drive the pump and motor to deliver water even under adverse conditions, reducing output as necessary to protect the system components from damage, and only shutting down in extreme cases. Full operation is restored automatically whenever abnormal conditions subside.

2.1 Inspection

Before you begin, receive and inspect the PDS23 solar pump controller unit. Verify that the part number is correct and that no damage has occurred during transit.

NOTE: PDS23 solar pump controller is one component of a PDS23 solar pumping system which has other two optional components, solar array and AC pump with motor.

2.2 Descriptions and Features

The PDS23 solar pump controller is based on a standard PDS23 platform

controlling a standard three-phase asynchronous motor driving a pump powered by a solar array or an optional AC generator backup.

The PDS23 solar pump controller continuously monitors system performance and incorporates a number of features for pumping system protection. In the event of a fault, the PDS23 solar pump controller will indicate the type of fault through the LED display mounted on the front cover of controller.

The PDS23 solar pumping system is optimized for pumping under adverse input power conditions unique to solar arrays:

- Internal diagnostics will tolerate a lower input voltage.
- Whenever possible, the controller attempts to drive the pump load by maximizing power output from the solar array.

An easy to use interface is provided to enhance configurability and enable remote system monitoring.

- A LED display provides a detailed indication of system status.
- A small keypad offers flexibility for selection of user options.

2.3 Protection Features

Electronic monitoring gives the controller the capability to monitor the system and automatically shut down in the event of:

- Dry well conditions – with low level switch
- Bound pump – with auto-reversing torque.
- High Voltage Surge
- Low Input Voltage
- Open motor circuit
- Short circuit
- Over heat

NOTE: This controller provides motor overload protection by preventing motor current from exceeding rating current and by limiting the duty cycle in the event of low water level. This controller does not provide over temperature sensing of the motor.

2.4 PDS23 Solar Pump Controller Model Description

2.4.1 Model Description

PDS 23 - 4 T 5R5
 ① ② ③ ④ ⑤

Segment	Description	Options
①	PDS series	
②	Series ID	2: Series of 2nd generation. 3: Apply to three-phase induction motor
③	Rated Output Voltage	2: 220V three phase; 4: 380V three phase
④	Input Voltage	S: 310VDC rating, MPPT range 280VDC ~360VDC(Note 1) T: 540VDC rating, MPPT range 500VDC ~600VDC(Note 2)
⑤	Motor Power Rating	004:4kW; 5R5:5.5kW; R: decimal point
<p>Note 1: Supporting Alternating Current input, with voltage rating of 220VAC single phase connected to terminal R&T.</p> <p>Note 2: Supporting Alternating Current input, with voltage rating of 380VAC three phase connected to terminal R, S and T.</p>		

2.4.2 PDS23 Solar Controller General parameters

General Parameters			
Protection			
Surge Protection	Integrated	Oversvoltage Protection	Integrated
Undervoltage Protection	Integrated	Locked pump Protection	Integrated
Open circuit Protection	Integrated	Short circuit Protection	Integrated
Overheated Protection	Integrated	Dry Run Protection	Integrated
Communication			
MODBUS Communication Card	Optional, RS-485 Isolated		
Others			
Ambient Temperature Range	-20°C ~60°C; >45°C, Derating as Required		
Cooling Method	Fan Cooling		
Ambient Humidity	≤ 95%RH		

Standard Warranty(month)	18
Certificates	IEC/EN 61800-5-1,IEC/EN 61800-2:2004,IEC/EN 61800-3:2004,CE

2.4.3 PDS23 Solar Controller Input and Output Data

PDS23-2SXX Input and Output Data

Controller Model	PDS23-2SR75	PDS23-2S1R5	PDS23-2S2R2
Input Data			
Max Input Voltage(Voc)	DC 450V		
Recommended Voltage, at MPP	DC 280-360V		
Recommended PV Array Power[kW]	0.9 ~1.2	1.8 ~2.4	2.7 ~3.5
Alternate AC Generator			
Input Voltage	Single Phase AC 200-240V(±10%)		
Max Amps(RMS)[A]	8.2	14	23
Power and VA Capability[kVA]	1.5	3	4
Output Data			
Output Voltage, Rated	Three Phase AC 200-240V		
Max Amps(RMS)[A]	4	7	9.6
Output Power, Rated[kW]	0.75	1.5	2.2
Output Frequency	0~50Hz/60Hz		

PDS23-4TXX Input and Output Data

Controller Model	PDS23-4T2R2	PDS23-4T004	PDS23-4T5R5	PDS23-4T7R5
Input Data				
Max Input Voltage(Voc)	DC 800V			
Recommended Voltage, at MPP	DC 500-700V			
Recommended PV Array Power [kW]	2.7 ~3.5	4.8 ~6.4	6.6 ~8.8	9 ~12
Alternate AC Generator				
Input Voltage	Three Phase AC 380/400/415/440V(±15%)			
Max Amps(RMS)[A]	5.8	10.5	14.6	20.5
Power and VA Capability[kVA]	4	5.9	8.9	11
Output Data				
Output Voltage, Rated	Three Phase AC 380/400/415/440V(±15%)			

Max Amps(RMS)[A]	5.1	9	13	17
Output Power, Rated[kW]	2.2	4	5.5	7.5
Output Frequency	0~50Hz/60Hz			

Controller Model	PDS23-4T011	PDS23-4T015	PDS23-4T18R5	PDS23-4T022
Input Data				
Max Input Voltage(Voc)	DC 800V			
Recommended Voltage, at MPP	DC 500-700V			
Recommended PV Array Power [kW]	13.2~17.6	18~24	22.2~29.6	26.4~35.2
Alternate AC Generator				
Input Voltage	Three Phase AC 380/400/415/440V(±15%)			
Max Amps(RMS)[A]	26	35	38.5	46.5
Power and VA Capability[kVA]	17	21	24	30
Output Data				
Output Voltage, Rated	Three Phase AC 380/400/415/440V(±15%)			
Max Amps(RMS)[A]	25	32	37	45
Output Power, Rated[kW]	11	15	18.5	22
Output Frequency	0~50Hz/60Hz			

Controller Model	PDS23-4T030	PDS23-4T037	PDS23-4T045	PDS23-4T055
Input Data				
Max Input Voltage(Voc)	DC 800V			
Recommended Voltage, at MPP	DC 500-700V			
Recommended PV Array Power [kW]	36~48	44~59.2	54~72	66~88
Alternate AC Generator				
Input Voltage	Three Phase AC 380/400/415/440V(±15%)			
Max Amps(RMS)[A]	62	76	92	113
Power and VA Capability[kVA]	40	57	69	85
Output Data				
Output Voltage, Rated	Three Phase AC 380/400/415/440V(±15%)			
Max Amps(RMS)[A]	60	75	91	112

Output Power, Rated[kW]	30	37	45	55
Output Frequency	0~50Hz/60Hz			

Controller Model	PDS23-4T075	PDS23-4T093	PDS23-4T110	PDS23-4T132
Input Data				
Max Input Voltage(Voc)	DC 800V			
Recommended Voltage, at MPP	DC 500-700V			
Recommended PV Array Power [kW]	90~120	112~149	132~176	159~211
Alternate AC Generator				
Input Voltage	Three Phase AC 380/400/415/440V(±15%)			
Max Amps(RMS)[A]	157	180	214	256
Power and VA Capability[kVA]	114	134	160	192
Output Data				
Output Voltage, Rated	Three Phase AC 380/400/415/440V(±15%)			
Max Amps(RMS)[A]	150	176	210	253
Output Power, Rated[kW]	75	93	110	132
Output Frequency	0~50Hz/60Hz			

Controller Model	PDS23-4T160	PDS23-4T200	PDS23-4T220	PDS23-4T250
Input Data				
Max Input Voltage(Voc)	DC 800V			
Recommended Voltage, at MPP	DC 500-700V			
Recommended PV Array Power [kW]	192~256	240~320	264~352	300~400
Alternate AC Generator				
Input Voltage	Three Phase AC 380/400/415/440V(±15%)			
Max Amps(RMS)[A]	307	385	430	468
Power and VA Capability[kVA]	231	250	280	355
Output Data				
Output Voltage, Rated	Three Phase AC 380/400/415/440V(±15%)			

Max Amps(RMS)[A]	304	377	426	465
Output Power, Rated[kW]	160	200	220	250
Output Frequency	0~50Hz/60Hz			

Controller Model	PDS23-4T280	PDS23-4T315	PDS23-4T355	PDS23-4T400
Input Data				
Max Input Voltage(Voc)	DC 800V			
Recommended Voltage, at MPP	DC 500-700V			
Recommended PV Array Power [kW]	336~448	378~504	426~568	480~640
Alternate AC Generator				
Input Voltage	Three Phase AC 380/400/415/440V(±15%)			
Max Amps(RMS)[A]	525	590	665	785
Power and VA Capability[kVA]	396	445	500	565
Output Data				
Output Voltage, Rated	Three Phase AC 380/400/415/440V(±15%)			
Max Amps(RMS)[A]	520	585	650	725
Output Power, Rated[kW]	280	315	355	400
Output Frequency	0~50Hz/60Hz			

Note: according to different regions, the recommended PV array power is 1.2 ~ 1.6 times the power of the controller.

2.5 Outline & Installation Dimensions

2.5.1 Outline & installation dimensions diagram

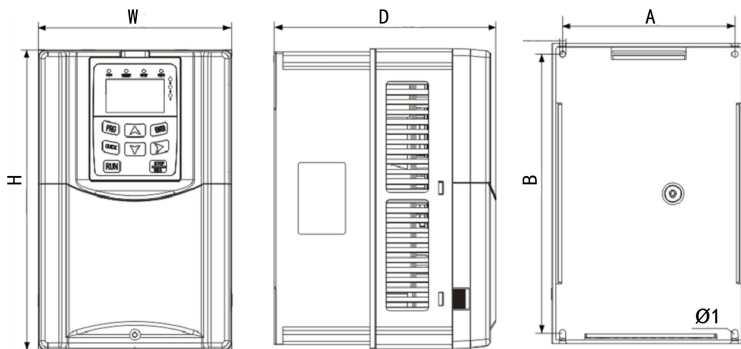

Figure 2 0.75~15kW Outline & installation dimensions diagram

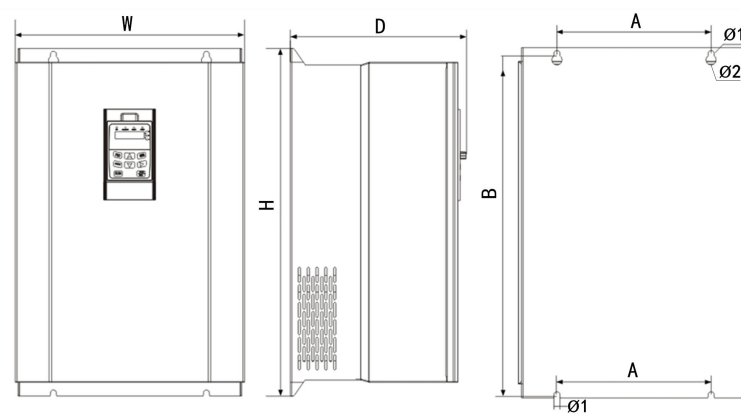

Figure 3 18.5~55kW Outline & installation dimensions diagram

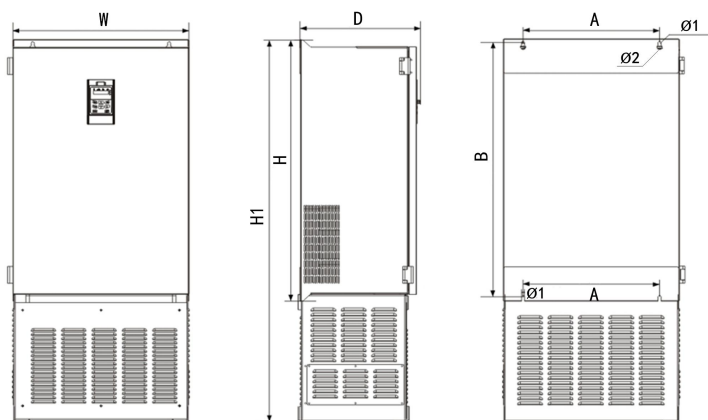

Figure 4 75~160kW Outline & installation dimensions diagram

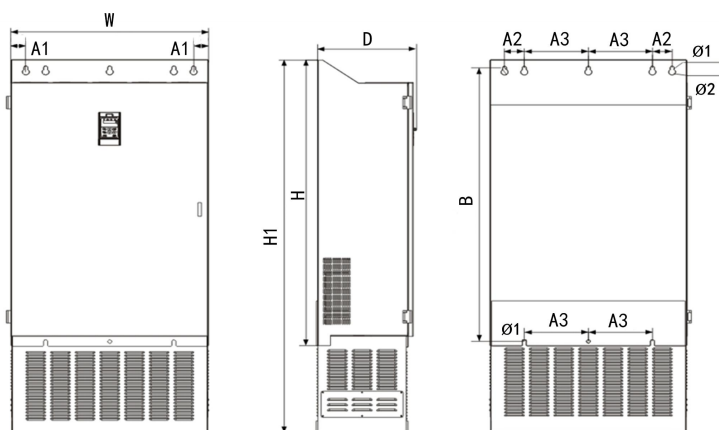

Figure 5 200~400kW Outline & installation dimensions diagram

2.5.2 Table of outline & installation dimensions

Controller Model	Installation Dimensions (mm)				Outline Dimensions (mm)				Holes(mm)		Gross Weight (kg)
	A(A1)	A2	A3	B	H	H1	W	D	ø1	ø2	
PDS23-2SR75	113			172	186		126	168	5.3		2.8
PDS23-2S1R5	113			172	186		126	168	5.3		2.8
PDS23-2S2R2	148			236	254		166	191	5.5		4.2
PDS23-4T2R2	113			172	186		126	168	5.3		2.8
PDS23-4T004	148			236	254		166	191	5.5		4.2
PDS23-4T5R5	148			236	254		166	191	5.5		4.2
PDS23-4T7R5	190			305	322		208	211	6		9
PDS23-4T011	190			305	322		208	211	6		9
PDS23-4T015	190			305	322		208	211	6		9
PDS23-4T185	235			447	463		289	210	7	12	17.2
PDS23-4T022	235			447	463		289	210	7	12	17.2
PDS23-4T030	235			447	463		289	210	7	12	17.6
PDS23-4T037	260			580	598		390	299	10	17	42
PDS23-4T045	260			580	598		390	299	10	17	42
PDS23-4T055	260			580	598		390	299	10	17	42
PDS23-4T075	343			674	700	978	485	318	10	17	71
PDS23-4T093	343			674	700	978	485	318	10	17	71
PDS23-4T110	449			903	927	1359	580	394	10	17	169
PDS23-4T132	449			903	927	1359	580	394	10	17	169
PDS23-4T160	449			903	927	1359	580	394	10	17	171
PDS23-4T200	130.5	0	210	1162	1192	1482	680	413	12	24	197
PDS23-4T220	130.5	0	210	1162	1192	1482	680	413	12	24	220
PDS23-4T250	130.5	0	210	1162	1192	1482	680	413	12	24	220
PDS23-4T280	60	80	260	1300	1355	1766	800	400	16	28	290
PDS23-4T315	60	80	260	1300	1355	1766	800	400	16	28	290
PDS23-4T355	60	80	260	1300	1355	1766	800	400	16	28	290
PDS23-4T400	60	80	260	1300	1355	1766	800	400	16	28	290

Chapter 3 Mechanical and Electrical Installation

3.1 Mechanical Installation

3.1.1 Overheat protection

Install the PDS23 solar pump controller in a control box with control terminals and power wiring. Install the control box out of direct sunlight to prevent overheating and reduced performance. The optimum location is on the mounting pole for the solar array underneath the array for protection from the sun, heat, and weather elements. Placing the control box in direct sunlight or high ambient temperatures will result in reduced performance due to temperature foldback protection of the PDS23 solar pump controller. For optimum performance, maximize the shading of the control box.

It is recommended that use a wire tube to protect the electric wire from the destruction of wildlife and natural weathering, and bury the wire tube into the ground to strengthen protection. If you do not use a wire tube, you can use a higher quality outdoor cable.

3.1.2 Location Selection

The PDS23 solar pump controller is intended for operation in ambient temperatures up to 60°C, but in order to avoid overheating caused by the failure, it is recommended to install the controller in the shadow position.

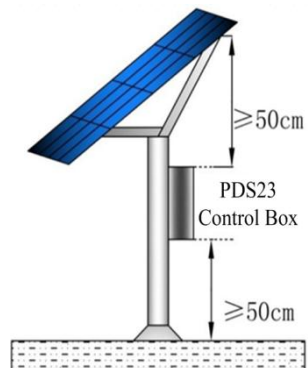

Figure 6 Control Box Location

The PDS23 solar pump controller must be installed into a control box which has a tight enclosure to avoid direct sunshine, rain, dust, moisture, animals, plants, etc. The control box should have a bottom gland plate for installing wire cord or conduit. To decide the size of control box, Please refer to the following Figure 6.

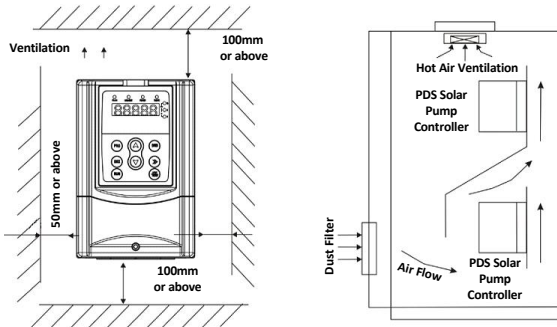

Figure 7 Ventilation Arrangement and Required Distances

3.2 Electrical Installation

3.2.1 Terminals

The following are typical figures of terminal blocks.

Note: Terminals are different in shapes and combinations, depending on different sizes of PDS23 Solar Controllers.

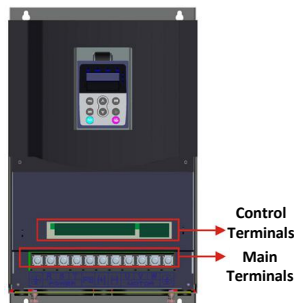

Figure 8 Terminals Arrangement of PDS23 Solar Pump Controller (11kW size, with lower part of front cover been cut away.)

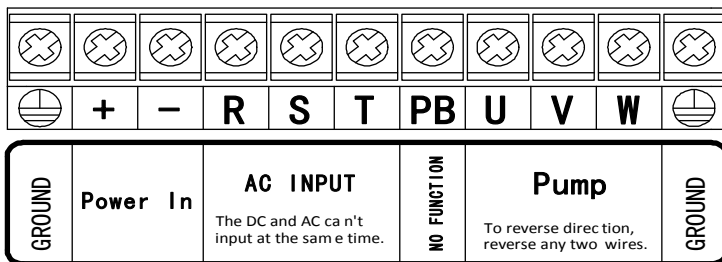

Figure 9 Main terminals (The sequence may be different from actual product)

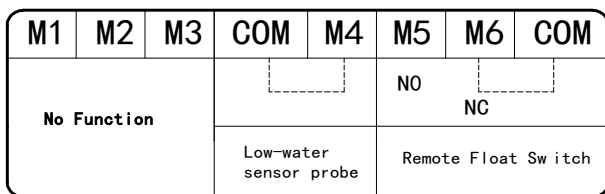

Figure 10 Control terminals (The sequence may be different from actual product)

3.2.2 Power in DC Wiring

For Solar Pumping Systems, a two-pole DC disconnect switch must be installed between the solar array and the PDS23 solar pump controller.

Connect the cables which comes from the two-pole DC disconnect Switch downstream terminals marked with “+” and “-” (positive and negative poles of Solar panel output), to PDS23 solar pump controller’s terminals block labeled as “+”, “-”.

Note: The R, S, T terminals are with anti reverse connection protection; DC power supply can be connected in the R, S, T terminals, can not consider the phase sequence.



Before connect DC wiring, following the steps below to prevent hazardous electric shock resulting in serious injury or device burning.

- Make sure that the external DC disconnect switch is off.
- To ensure that the polarity of the solar array cable must be properly connected to the controller's +, - pole, otherwise possible damage the controller.
- Make sure that AC power is disconnected (If AC power supply is wired as backup power, AC and DC power supply can not simultaneously put into the controller, otherwise it will damage the controller.)

3.2.3 Junction box connection

If there are a large number of solar modules, it is needed to use a junction box to converge the bus to the solar array. The junction box need to install fuses, lightning protection device and DC switch. The fuse and the DC switch can prevent the short circuit protection; the lightning protection device can play the direct current side the lightning protection function. The junction box must be sealed, and water can not enter

3.2.4 Ground Wiring

Ground terminal (GND) is labeled as this icon  . Please refer to the instruction to this icon, or other equivalent icon or sign by local electrical codes or international standard. Correct grounding helps to prevent shock hazard if there is a fault in the motor.

3.2.5 Motor Wiring

Connect the cable with four wires from the Motor to the controller terminal block to terminals U, V, W, and GND (See Figure 9). Check motor lead color to ensure correct installation.。

Note: To reverse direction of motor rotation, reverse any two wires

US	Black (BLK)	Red (RED)	Yellow (YEL)	Ground (GND)
International	Gray (GRY)	Black (BLK)	Brown (BRN)	Ground (GND)

Figure 11 Motors with international leads

3.2.6 Low water level probe wiring (optional)

In order to avoid dry pumping lead to pump damage can be connected a wells probe to the terminals of the PDS23 solar pump controller, so as to detect the water level in wells and the wire maximum length can not more than 50m. If there is no water level probe for the detection of the water level, please keep the two terminals of the controller short. The controller can also detect water through the built-in software water detection function; see section 4.3.

3.2.7 Water tank level float wiring (optional)

Use a floating ball switch to prevent reservoir overflow is recommended. When the reservoir is full, the pump will stop; when the water level is lower than the low level, the pump will be restarted. It can prevent the overflow, limit the unnecessary pump wear. The PDS23 controller allows the use of small signal line to connect to remote float switch, even if the position of the reservoir is far away.

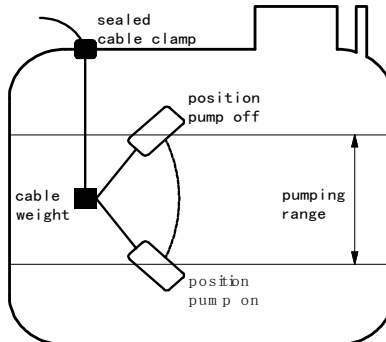

Figure 12 Floating Ball Diagram

Floating ball switch request:

1. Three signal line
2. The minimum requirements for 1 mm² line diameter, the distance up to 600m
3. If the application is in a long distance transmission, the need to use the shielded wire. The end of the shielding layer close to the controller needs to be grounded, the end close to the floating ball switch; the end close to the float switch is not required to be grounded.

If the float switch is not used, the M6 and COM are kept short.

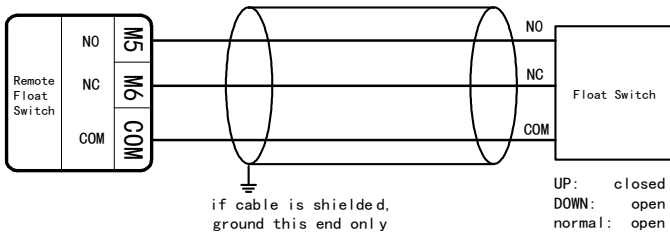

Figure 13 Float ball wiring diagram

3.2.8 Electrical conduit

When the system installed in the outdoor, electrical conduit can be used to protect the outdoor electric wires, so as to avoid the impact from the weather, human activities, chewing animals. If you do not use the electrical conduit, use the higher quality outdoor wire.

3.2.9 System Wiring Diagram

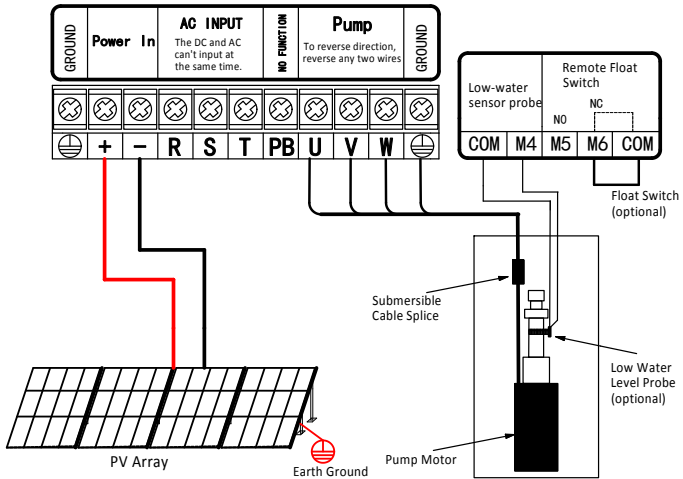

Figure14 System Wiring Diagram

NOTE:

1. The float switch is optional; if not use, please keep the terminal M6 and COM short.
2. Low water level probe is optional; if not use, please keep the terminal M4 and COM short.

In the case of conventional 250W polycrystalline components, the peak voltage is 30.6V and the open circuit voltage is 37V. Description of the number of input components in series:

The PDS23-2S series controller is connected in series with the serial number of the input components of the 10 ~12 block, and the 250W 280 ~360VDC (MPPT) is satisfied.

The PDS23-4T series controller is connected in series with the serial number of the input components of the 18 ~20 block, and the 250W 500 ~600VDC (MPPT) is satisfied.

Chapter 4 Start-up and Operation

4.1 Keypad Description

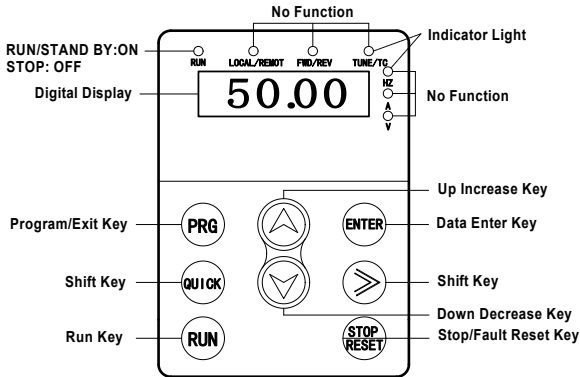









Figure 15 Keypad Schematic Diagram

Symbol	Button Name	Function Description
	program/ exit key	Enter or exit of menu, parameter modification
	data enter key	Progressively enter menu and confirm parameter
	UP increase key	Progressively increase data or function codes.
	DOWN decrease key	Progressively decrease data or function codes.

	shift key	Use it to select displayed parameters cyclically during running or stop status. In parameter setting mode, press this key to select the bit to be modified.
	run key	Start to run the controller in keypad control mode.
	stop/reset key	In running status, use it to stop the controller. In malfunction alarm status, use it to reset the controller.

4.2 Keypad Operation Process

4.2.1 Parameter Setting

Three levels of menu are as following:

- Function code group (first-class)
- Function code (second-class)
- Setting parameter of function code (third-class)

In order to set up the electric automatic start function FD.07=11 as an example, the modified parameter flow chart is as follows:

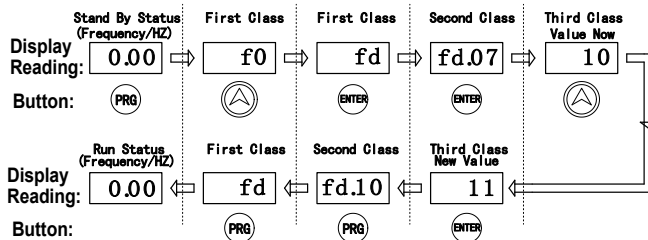

Figure 16 Schematic Diagram of Function Parameters

4.2.2 Fault Reset

After the controller has failed, the controller will display the relevant fault code information. The conventional fault code (E002/3/4/5/6/7/8/9/10/11/12/18) can automatically reset after 10s operation, and can also choose to reset the STOP/RESET on the keyboard. If the conventional failure persists, the controller will reset once every 10s. Special fault code (E001/13/14) requires the user through the STOP/RESET key on the keyboard to reset the fault; the controller can continue to run after the reset.

4.3 Trial operation

- Check and make sure wiring are correct. If needed, take a megger to test the insulation of motor, cable, etc.;
- Use a multimeter to test the PV output voltage at the DC switch.;
- Power on the controller by switch the DC switch.
- If necessary, modify and set the parameters of motor to the controller

For Example, if the motor which rated frequency is 60Hz, these parameters need modification:

High limit of running frequency F0.12=60;

Other related parameters are: motor rated power F2.01, motor rated frequency F2.02=60, motor rated speed F2.03, motor rated voltage F2.04, motor rated current F2.05.

Note: default motor rated frequency setting is 50Hz.

Slowly start to check the direction

Pressing the RUN/STOP key to start the motor shortly and slowly, and check the direction of the pump.

If the pump is in dry-run state, the maximum operating time can not exceed 15s, otherwise it may cause damage to the pump.

If the pump is in dry-run, the maximum operating time can not exceed 15 seconds; otherwise it may cause damage to the pump. If the pump steering error, close the DC switch, according to the pump / motor wiring to change the wiring of the motor section of the two leads.

After the above parts are complete, you can try to run the system.

Let the system work for an hour, check the water supply capacity.

Commissioning finish

When the light is insufficient, the solar power module output power will be reduced, and the pump operation speed will be very slow until stop. The controller will attempt to start every 120s, and during the trial run, the running indicator is always on.

When a shadow suddenly passes through the battery array, the controller will lose track of the input voltage, and the pump will stop working. But the controller does not show the fault, the controller will try to restart the pump.

4.4 Running status panel display parameters

Description: press "shift" key to switch

Display code	Name	Description	Unit	Remarks
H	Operating Frequency	The Operating Frequency	Hz	◎
	Output Voltage	Controller Output Voltage	V	
A	Running Current	Controller Actual Output Current	A	◎
	Input Voltage	DC Input Voltage	V	

4.5 User Definable Parameters

- : The parameters can be modified at stop or running status.
- : The parameters cannot be modified at running status.
- ◎ The parameters which are actual-detecting record value and cannot be modified.

Function Code	Function	Descriptions	Unit	Factory Setting	Modification Type
F0 Group: Basic Parameters					
F0.12	High limit of running frequency	30.00 ~60.00	Hz	50.00	○
F0.14	Low limit of running frequency	0.00 ~F0.12	Hz	20.00	
F0.18	Acceleration time	0.1 ~3600	s	10.0	○
F0.19	Deceleration time	0.1 ~3600	s	10.0	○
F0.20	Default setting	0:Not restore to default setting 1: Restore to factory setting 2:Fault record clearing		0	●
F2 Group: Motor Parameters					
F2.01	Motor rated power	0.4 ~400.0	kW	Different according to inverter model	●
F2.02	Motor rated frequency	10.00 ~F0.10	Hz	50.00	●
F2.03	Motor rated speed	0 ~36000	rpm	1500(Different according to inverter model)	○

Function Code	Function	Descriptions	Unit	Factory Setting	Modification Type
F2.04	Motor rated voltage	0 ~480	V	Different according to inverter model	●
F2.05	Motor rated current	0.8 ~2000	A	Different according to inverter model	●
F7 Group: Display Interface Parameters					
F7.00	User password	0 ~9999		0	○
F7.02	Manufacturer debug	Reserved		0	○
F7.09	Module temperature	0 ~100.0	℃		●
F7.10	Inverter firmware version				◎
F7.11	Accumulative running time	0 ~9999	hour		◎
FA Group: Protection and Malfunction Parameters					
FA.14	Fault record of the one before last	0: No fault 1: Inverter module protection (E001) 2: Over-current when accelerate (E002) 3: Over-current when decelerate (E003) 4: Over-current at constant speed (E004)			◎

Function Code	Function	Descriptions	Unit	Factory Setting	Modification Type
FA.15	Last fault record	5: Over-voltage when accelerate (E005) 6: Over-voltage when decelerate (E006) 7: Over-voltage at constant speed (E007) 8:Hardware overvoltage (E008) 9:Under voltage (E009)			○
FA.16	Current fault record	10:Inverter overload (E010) 11:Motor overload (E011) 12:Phase-lack of input (E012) 13:Phase-lack of output (E013) 14:Heatsink overheating (E014) 15:External fault (E015) 16:Communication fault (E016) 17:Reserved 18:Current detection fault (E018) 20:Well level fault(E020) 21:Tank level fault(E021) 22:EEPROM fault (E022) 26:Water shortage fault (E026)			○
FA.17	Running frequency when fault occurs		Hz		◎
FA.18	Output current when fault occurs		A		◎
FA.19	DC bus voltage when fault occurs		V		◎

Function Code	Function	Descriptions	Unit	Factory Setting	Modification Type
FD Group: Solar pumping special parameters					
FD.07	Auto start when power on	10: Disable 11: Enable		10	○
FD.10	Water shortage detection time	0 ~250 (0: disabled)	s	10	○
FD.11	Lowest running frequency when yielding water	0.00 ~F0.10	Hz	20.00	○
FD.12	Water shortage detection current ratio corresponding to no-load current	80.0 ~300.0	%	150.00	○
FD.13	Interval of water shortage detection	1 ~9000	min	20	○

Parameter interpretation:

F0.14, Low limit of running frequency: this parameter defaults to 20Hz, when the light becomes weak, and the controller output frequency is lower than F0.14, the controller will be in standby mode. After the light becomes strong, the controller will rerun. Can set this parameter artificially, in order to avoid pump at low speed without water, reduce the pump abrasion at low speed.

F2.01-F2.05, Motor parameter: the user can be set according to the actual pump motor nameplate parameters

F7.00 user password: the user can set a 5 digits password; after the password is set up and confirmed, the password will be valid for a minute.

FD.07, Automatic start when power on: the factory defaults to 10 (disabled).It can be set to 11 (enabled), then as long as the solar module power supply, the

controller will automatically start and achieve automatic operation of the whole day.

FD.10 water shortage detection time: when applied to a deep well pump, not using the water level probe to detect the water shortage, the controller can use the built-in water shortage detection function to complete the water shortage detection. When this parameter is not 0, the software will start the function of water shortage.

Software shortage detection principle: If the water shortage happens, the controller will still run FD.10 time, after that it will appear the water shortage fault E026. The fault will be reset and the controller will restart automatically after 20 minutes. If there is no water shortage but fails E026, it may appear false; then you can simply reduce FD.12 value.

WARNING: DO NOT touch any other piece inside the PDS23 Solar pump controller while power is applied. To service any other areas of the controller, disconnect ALL power sources and wait 5 minutes before continuing.

For the selection of PDS23 solar pump controller, it can be matched with the power of the pump. However, if the controller drives a submersible pump, please use a higher-rated controller; if the length of cable is more than 100m, add an output reactor. For example, to an application of 50m deep well, a 5.5kW controller should be selected to control a 4kW motor.

Chapter 5 Diagnostics and Troubleshooting

The PDS23 solar pump controller will attempt to drive the pump to deliver water even under adverse conditions. To ensure years of reliable service, it must also protect the system components from conditions that might result in equipment damage. When adverse conditions arise, the controller will continue to deliver as much water as possible at reduced output if necessary, and will shut down only in extreme cases. Full operation will resume automatically whenever abnormal conditions subside.

If the controller has stopped to indicate a fault code on the display, the associated time-out delay will vary depending on the nature of the fault. The number following the “E” symbol corresponds to the error code for the offending condition.

5.1 Fault Codes

Fault code	Fault description	Possible causes	Remedy
E001	IGBT module fault	Too short acceleration time	Increase acceleration time
		Damaged IGBT module	Ask for support
		Malfunction caused by interference	Inspect external equipment and eliminate interference
		Improperly grounding	Check grounding wire
E002	Over-current during acceleration	Too fast acceleration	Increase acceleration time
		Too low input voltage	Check the input power supply or wiring

Fault code	Fault description	Possible causes	Remedy
		Lower-rating controller	Replace with higher-rating controller
E003	Over-current during deceleration	Too-fast deceleration	Increase deceleration time
		Too-heavy and large-inertia load	Add proper braking units
		lower-rating controller	Replace with higher-rating controller
E004	Over-current at constant running speed	Sudden change of load	Check the load
		Too low input voltage	Check the input power supply or wiring
		Lower-rating controller	Replace with higher-rating controller
E005	Over-voltage during acceleration	Abnormal input voltage	Check input power
		Restart the motor when instantaneous trip-off occurs	Avoid prompt restart when trip-off
E006	Over-voltage during deceleration	Too-fast deceleration	Add proper braking units
		Abnormal input voltage	Check input power supply or wiring
E007	Over-voltage at constant running speed	Abnormal input voltage	Install proper input AC reactor
E008	Hardware over-voltage	Abnormal input voltage	Check input power supply or wiring
		Too-fast deceleration	Increase deceleration time
E009	Under voltage of DC bus	Too-low input voltage	Check input power supply or wiring
E010	Controller overload	Too fast acceleration	Increase acceleration time

Fault code	Fault description	Possible causes	Remedy
		Restart the motor when instantaneous trip-off occurs	Avoid prompt restart when trip-off
		Too-low input voltage	Check input power supply or wiring
		Too-heavy load	Replace with higher-rating controller
E011	Motor overload	Too-low input voltage	Check input power supply or wiring
		Lower-rating controller	Replace with higher-rating controller
E013	Output phase loss	Broken wires in the output cable	Check the wiring and installation
		Broken wires in the motor winding	
		Loose output terminals	
E014	Controller overheat	Instantaneous over-current of controller	Refer to over-current remedy
		Output short circuit	Re-wiring of output
		Cooling fans of controller stopped or damaged. Obstruction of ventilation channel	Replace cooling fan and clear the ventilation channel
		Too-high ambient temperature	Decrease the ambient temperature if possible
		Loose cables or terminals	Inspect and tighten the wire and terminals
		Abnormal power circuit	Ask for support
		Abnormal control PCB board	
E016	Communication	Improper baud rate setting	Set proper baud rate

Fault code	Fault description	Possible causes	Remedy
	fault	Receive wrong data	Push STOP/RESET to reset and ask for support
		Long-time communication interruption	Check communication devices and cables
E018	Current detection fault	Loose wires or connectors of control board	Check the wiring and connectors
		Amplifying circuit abnormal	Ask for support
		Hall sensor is damaged	
		Power circuit abnormal	
E020	Well Level Fault	Dry well or slow water recovery	Wait for water to recover or reinstall the pump
E021	Tank Level Fault before auto start	High level limit is reached.	Wait until water level comes below the low level limit, and then the PDS23 Solar controller will start the pump again
E022	EEPROM fault	Read/ Write fault of control parameters	Push STOP/RESET to reset
		EEPROM damaged	Ask for support
E026	Water shortage fault	Water shortage of water source	Stop the controller Repair broken wiring or replace water level switch
		Verify if the setting of FD.12 "Water shortage detection current ratio" is too high, while FD.10 "Water shortage detection time" is non-zero and the current sensing is enabled.	Reduce setting value of FD.12

5.2 Common Faults and Remedies

The PDS23 solar pump controller may have following faults or malfunctions during operation, please refer to the following remedies.

5.2.1 Pump can not run

The main problem of the new system is that the wiring is not standardized and the controller terminal line falls, so that the pump can not run. Sometimes the RUN indicator light on the keyboard is bright, and the controller also has voltage output, but may be the solar array does not have enough power to start the pump; then the controller will attempt to start the pump every 120s. There are the following reasons for the pump can not run:

- ① If there is no enough sun light, and the controller's input power is not enough.
- ② Motor wiring errors cause the pump to reverse, change the wiring.
- ③ The motor shaft vibrates and can not rotate, it may be caused by the wiring errors; Need to re check the motor wiring.
- ④ Pumps and pipes are clogged with mud and debris, and the pump can't run

5.2.2 Controller over current, overload fault (E002/3/4/10/11)

The controller appears over current and overload failure may be due to the following reasons:

- ① The pump or pipe plug causes the pump current increase and the controller protection; Need to pull out the pump and check
- ② Because of the increase in operating current of the pump, which is caused by the pump wire is too long, the controller will be protected, and the controller will be enlarged to use.

5.2.3 DC switch trip when power on

- ① A multimeter can be used to check the internal circuit of the controller, if there is a short circuit, the machine has been damaged
- ② Check if the machine has a burning smell; if there is a burning smell, please contact the agent to replace the controller

5.2.4 The keyboard without display after power on

- ① Use a multimeter to measure the input voltage of the controller; check the voltage is normal.
- ② Check if the machine has a burning smell; if there is a burning smell, please contact the agent to replace the controller

Chapter 6 Regular maintenance

6.1 Controller and Pump

• Controller

Periodically checking of Status display, error code display and fault record, long term verification of cooling fan and cleaning of heat sink are needed.

• pump

The pump's motor is permanently sealed, no need to maintain. Pump head is a mechanical device, may be used for a period of time, due to the sand in the water, and other impurities cause a certain wear, the performance of the pump needs to be regularly detected. If the flow of the pump is less than the normal value, may need to be replaced.

6.2 Solar panels

Periodically cleaning of the surface of panels and checking wiring are required.

6.3 Cable

Need to regularly check the power cable and ground wire to make sure all the wires are reliably connected and without being corroded.

Chapter 7 Backup AC power

In order to ensure continuous water supply, solar water pump system can be manually switched to standby AC power supply when the light is insufficient or wet days. When switching, the need to ensure that the DC and AC power supply reliable mutual lock. Backup AC power source can be a local power grid, or a diesel generator (please refer to the 2.4.3 technical form).

Warning: at any time, only one power supply can be entered, otherwise it may cause the controller to damage.

Take three phase 380VAC backup AC power supply for example, the wiring is shown in the following diagram:

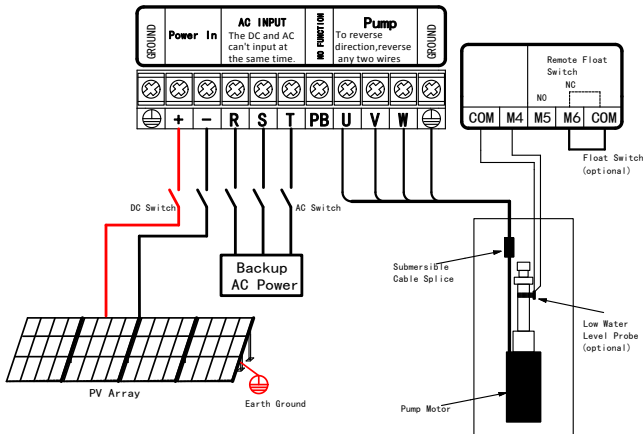

Figure 17 schematic diagram of alternate AC power supply

If the pump motor rated voltage is three-phase 220-240VAC, then the single-phase 220VAC standby power supply L/N power line, need to be connected to the main terminal R/T of the controller

System Report

System and Components				
Date of Purchase				
Distributor (Contact details)				
System				
Controller Serial Number				
Motor Serial Number or Power				
Pump Type	Submersible		Surface	
Solar Power				
Solar Module				
Manufacturers				
Type				
Peak Voltage (V _{mp})				
Open Circuit Voltage (V _{oc})				
Quantity				
Connection		Series		Parallel

Installation					
Installation Date					
Installer (contact details)					
Submersible Pump			Surface Pump		
Well Depth		m/ft	Head (self suction)		m/ft
Pump Depth		m/ft			
Vertical Height (well mouth to the tower top)		m/ft	Suction lift		m/ft
			MAX. Suction lift		m/ft
Static Water Level		m/ft			
Dynamic Water Level		m/ft			
Vertical Pipe in Well(pump)			Suction Pipe		
Diameter		mm/inch	Diameter		mm/inch
Type			Type		
Length		m/ft	Length		m/ft
Additional Pipe (to water tower)			Vertical Pipe		
Diameter		mm/inch	Diameter		mm/inch
Type			Type		
Length		m/ft	Length		m/ft
Cable of Submersible Pump			Cable of Surface Pump		
Wire Diameter		mm ² / AWG	Wire Diameter		mm ² / AWG
Length (from the controller to pump)		m/ft	Length (from the controller to pump)		m/ft

